



Toxicogenomics to Support Hazard Assessment

Russell Thomas, PhD

Center for Computational Toxicology and Exposure

US Environmental Protection Agency

Email: thomas.russell@epa.gov

Conflict of Interest Statement

- No conflicts of interest to declare.
- The views expressed in this presentation are those of the presenter and do not necessarily represent the views or policies of the US Environmental Protection Agency, nor does mention of trade names or products represent endorsement for use.



Objective and Outline

Objective: Provide a high-level overview of the application of toxicogenomics at EPA

- Evolution in the application of toxicogenomics at EPA
- More recent frameworks for applying toxicogenomics
- Examples of ongoing EPA research for toxicogenomics application
- Building confidence in toxicogenomic methods and approaches



Evolution in Application of Toxicogenomics at EPA

- EPA released interim policy on genomics in 2002
- Expressed interest in using toxicogenomics data to enhance assessments and priority setting
- Consider toxicogenomics data on case-by-case basis in a weight of evidence approach
- Conveyed that toxicogenomics data alone not sufficient as basis for decisions

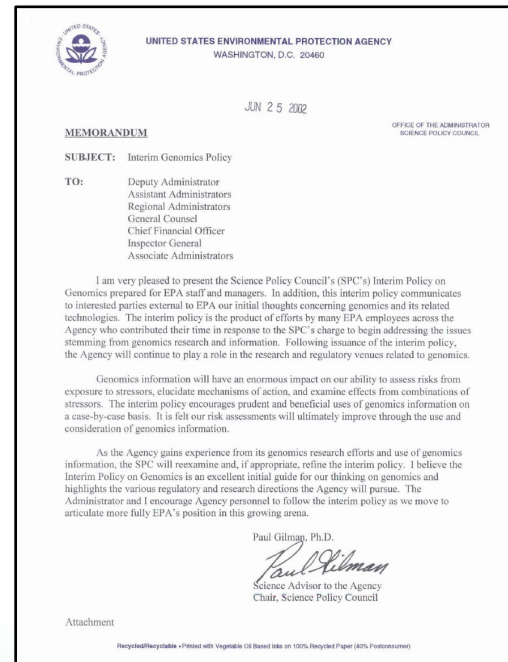

US EPA, Science Policy Council,
2002.



Evolution in Application of Toxicogenomics at EPA

- EPA published first report on potential applications of genomics in chemical risk assessment in 2004
- Emphasized potential applications in prioritization, monitoring, reporting provisions, mode of action, identifying sensitive populations, and addressing mixtures
- Noted challenges in linking genomics information to adverse outcomes, interpreting information for risk assessment, development of a framework for regulatory acceptance, and training of risk assessors/managers

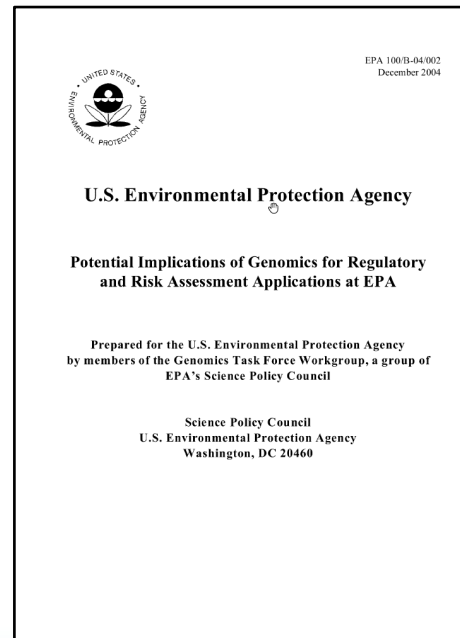

US EPA, Science Policy Council,
2004.



Evolution in Application of Toxicogenomics at EPA

- EPA used toxicogenomics information in a mode-of-action weight of evidence cancer risk assessment in 2004
- Time course toxicogenomics data was derived from rat olfactory mucosa at a single dose
- Early gene expression changes interpreted to be consistent with oxidative damage to DNA followed by cell proliferation
- Late gene expression changes interpreted to be consistent with tumorigenic progression

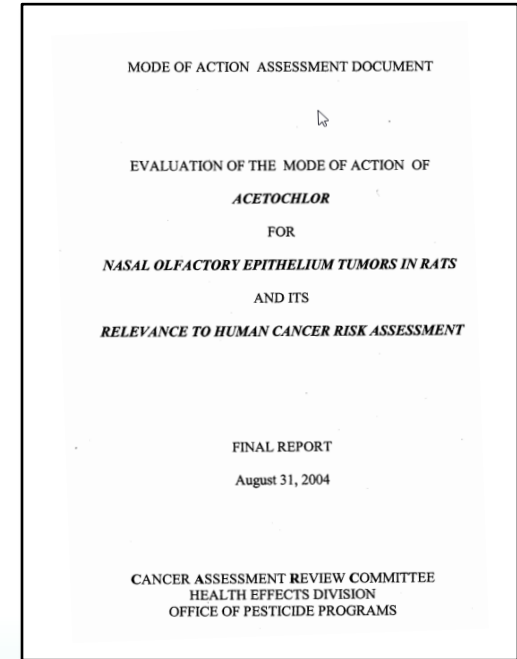

US EPA, Office of Pesticides
Programs, 2004.



Evolution in Application of Toxicogenomics at EPA

- EPA released interim guidance for microarray data submissions, quality, and analysis in 2007
- Draft guidance was never finalized
- Provided recommendations on performance approaches for quality assessment parameters, data analysis approaches, Agency data submissions, and data management practices
- Issued a draft Genomics Data Evaluation Record template
- Recommended development of training modules and materials for risk assessors, cross-Agency collaboration, and case study application

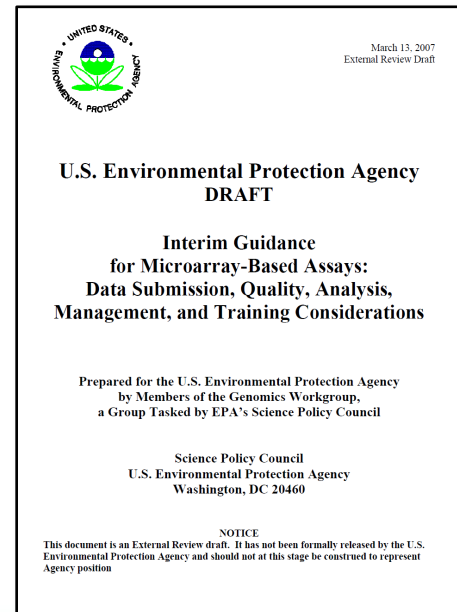

US EPA, Science Policy Council,
2007.



Evolution in Application of Toxicogenomics at EPA

- EPA released a case study for application of toxicogenomic data to human health risk assessment in 2009
- Outlined a systematic and flexible approach to accommodate different health and risk assessment practices
- Focused primarily on informing mode-of-action as part of a weight-of-evidence
- Provided some recommendations on best practices and highlighted current limitations
- Many of the limitations were noted in previous reports (e.g., linkage to adverse effects, consistency in interpretation/analysis methods)

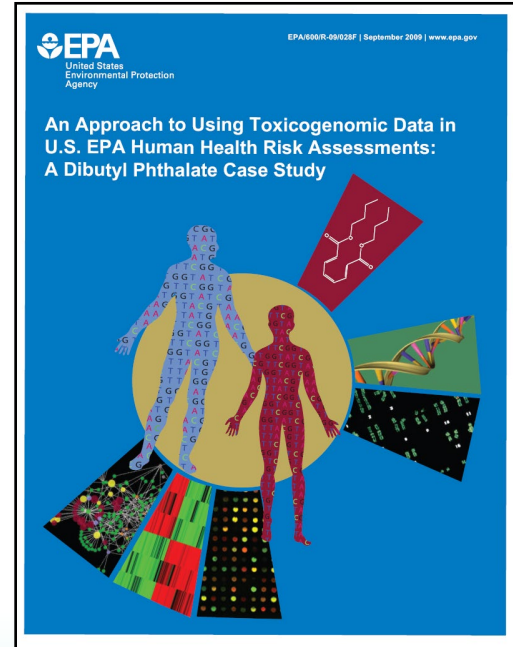

US EPA, Office of Research and Development, 2009.



Adverse Outcome Pathway Framework

- The Adverse Outcome Pathway (AOP) framework introduced in 2010
- Organizes existing knowledge linking direct molecular initiating events and adverse outcomes, at a level of biological organization relevant to risk assessment
- Facilitates interpretation of pathway and biological process gene expression changes in adverse outcome context
- Review and acceptance of AOPs by OECD provides confidence for application

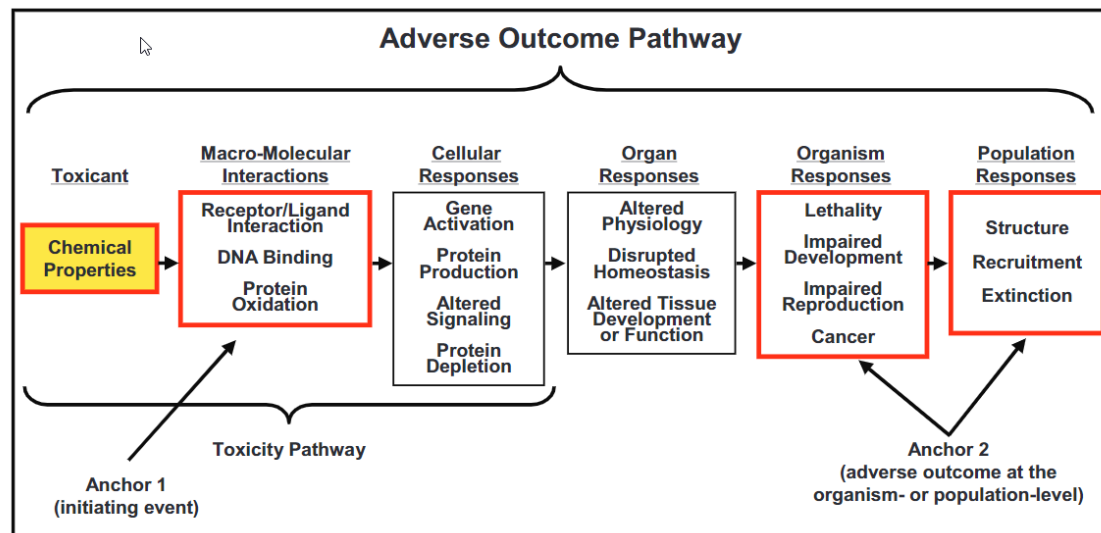

Ankley et al. Environ. Toxicol. Chem., 2010



In Vitro and In Vivo Focused Tiered Toxicity Testing Framework

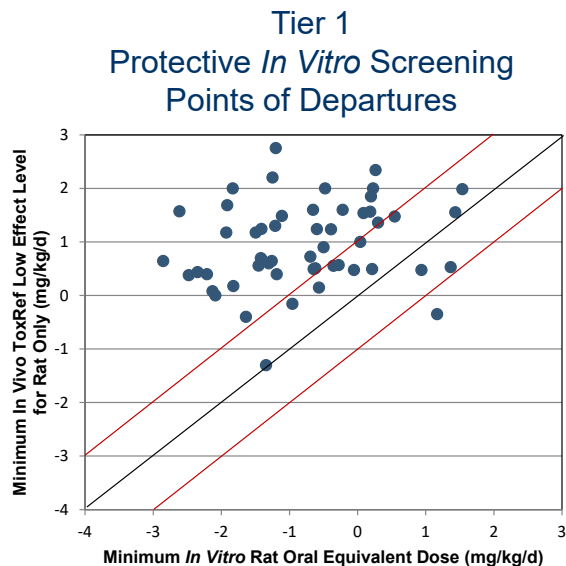
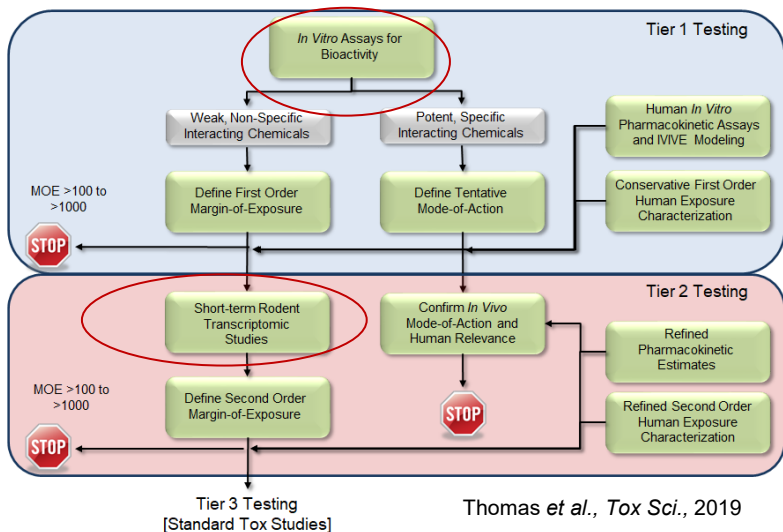

Wetmore et al., *Tox Sci.*, 2013

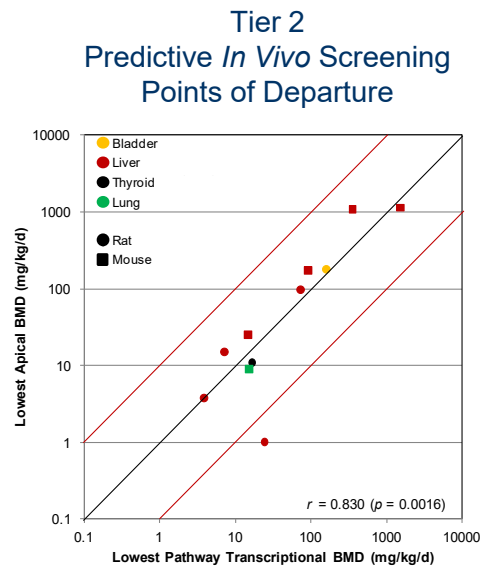

Thomas et al., *Tox Sci.*, 2013

An initial tiered toxicity testing framework outlined application of *in vitro* and *in vivo* toxicogenomic methods in a quantitative, risk-based context



In Vitro and In Silico Focused Tiered Toxicity Testing Framework

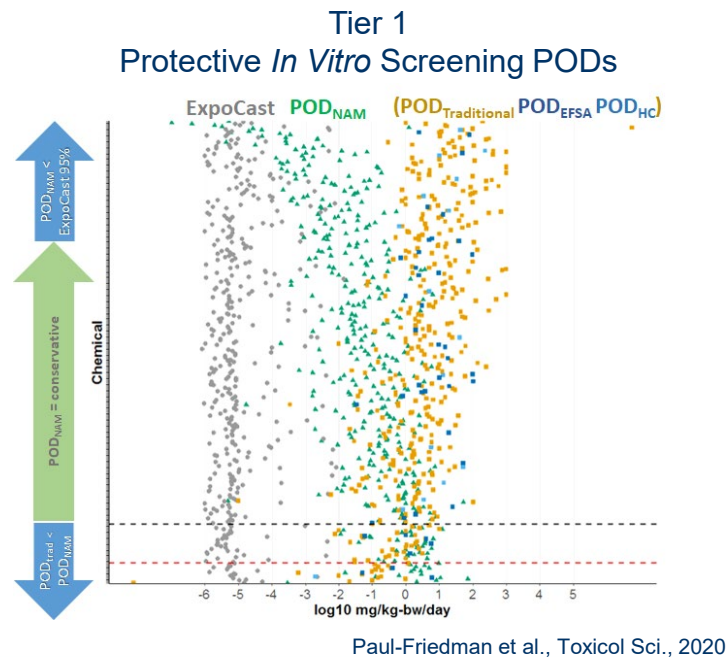
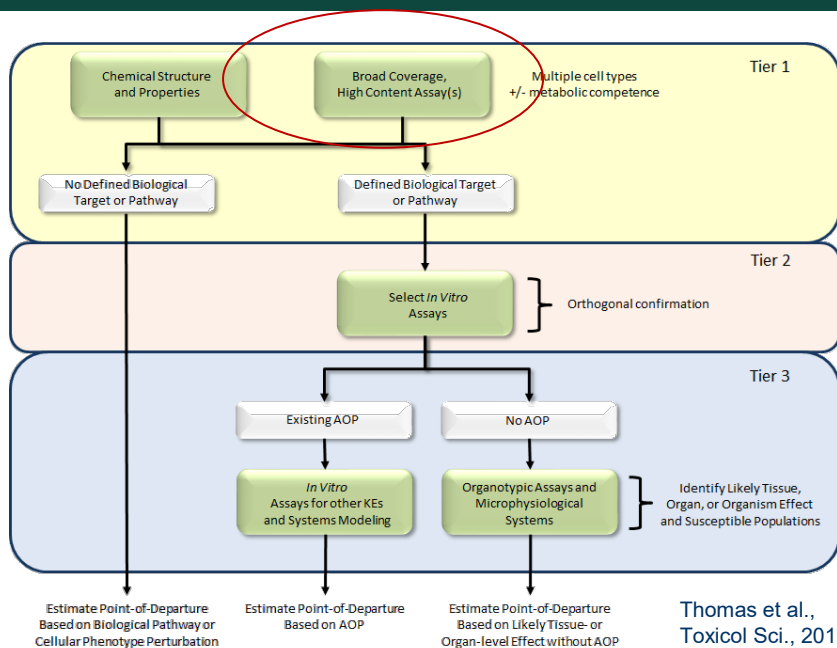

An initial tiered toxicity testing framework outlined application of *in vitro* toxicogenomic methods in a quantitative risk assessment context



Examples of Ongoing EPA Research for Toxicogenomics Application–PFAS Testing

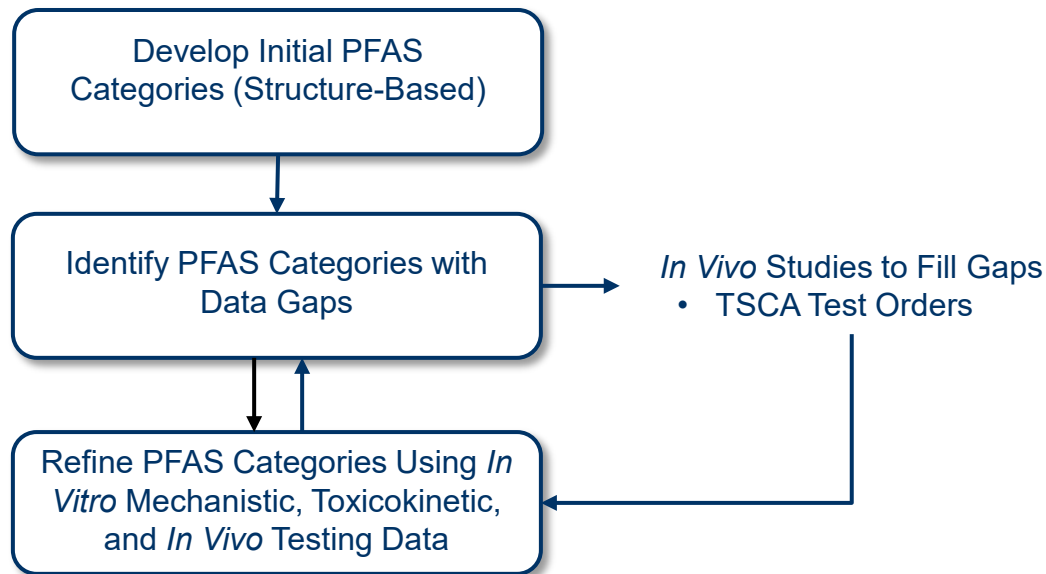

In vitro mechanistic data includes toxicogenomic dose response studies for 150 PFAS in two cell types

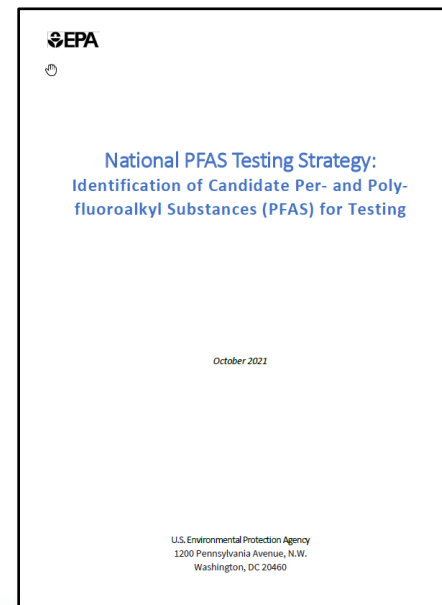

US EPA, 2021.



Examples of Ongoing EPA Research for Toxicogenomics Application—Screening PODs

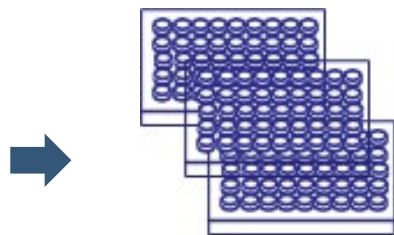
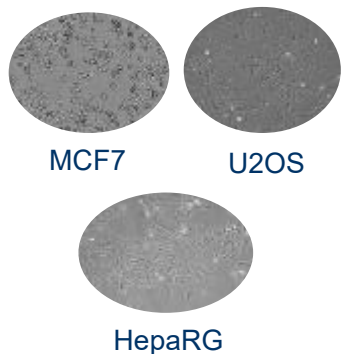

>1000 chemicals
Conc response
6, 24 hr exposure



Whole Genome
Transcriptomics (HTTr)

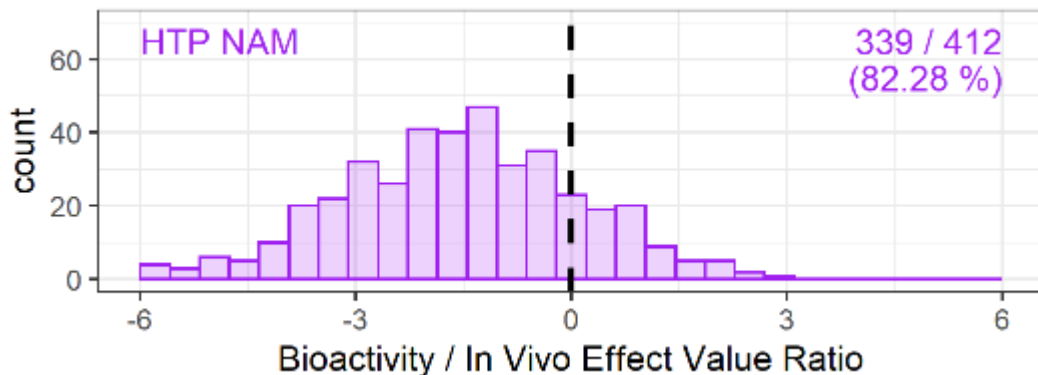
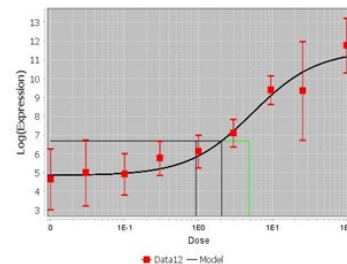

- HTTr-based bioactivity PODs across 3 cell types provide a protective POD ~82% of the time
- Average fold-difference was ~30
- Many of the non-protective PODs were from neuroactive chemicals



Examples of Ongoing EPA Research for Toxicogenomics Application–VOC Screening PODs

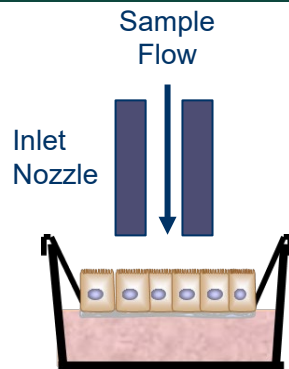
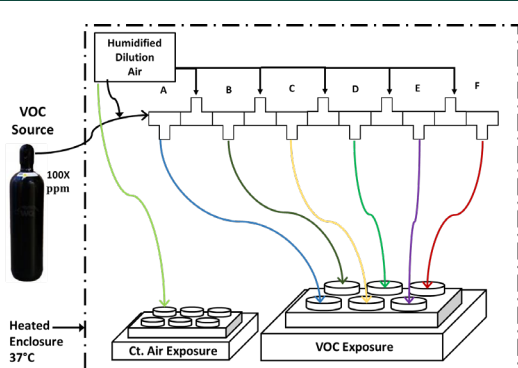

Whole Genome Transcriptomics (HTTr)

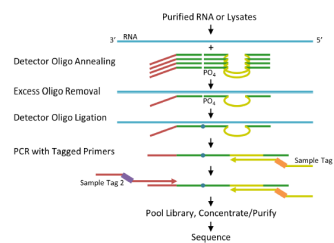

Concentration Response Modeling

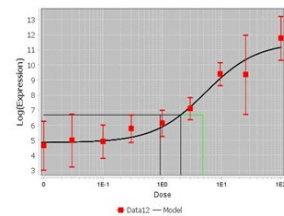

Speen et al. Toxicol. Sci., 2022

- HTTr-based bioactivity PODs were generally concordant with TLV values

	ACGIH TLV-TWA (ppm)	BEAS-2B HTTr POD (ppm)	HBEC HTTr POD (ppm)
Acrolein	0.1	0.58	--
Formaldehyde	0.3	NA	--
1,3-Butadiene	10	13.98	--
Acetaldehyde	25	NA	--
1-Bromopropane	0.1 (10)*	2.25	NA
Carbon Tetrachloride	10	9.56	NA
Trichloroethylene	50	44.8	28.1
Dichloromethane	100	142.13	266.7

* The ACGIH TLV TWA for 1-bromopropane was updated to 0.1 ppm in 2012. Prior to that the TLV-TWA for 1-bromopropane was 10 ppm.



Examples of Ongoing EPA Research for Toxicogenomics Application–Pesticide MOA

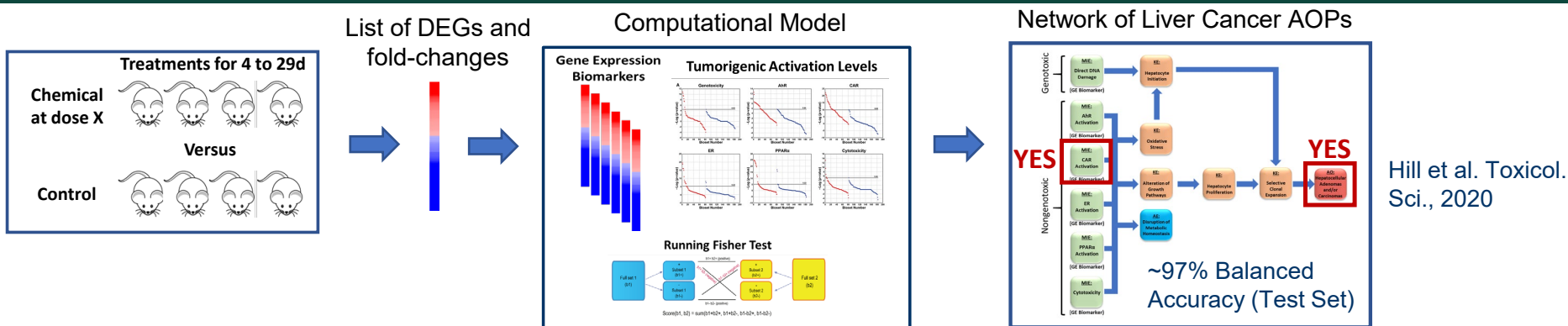

Study in Progress to Apply Signatures to Evaluate Liver Tumor MOA for Pesticides

Pesticide	Nontumorigenic Dose (mg/kg/d)	Tumorigenic Dose (mg/kg/d)
Alachlor	63	189
Amitrole	15	75
Cyhalofop-butyl	1.23	5.16
Lactofen	28.5	114
Thiabendazole	15	135
Fluxapyroxad	16.5	217.5
Etofenprox	39	280.5
Benalaxyl-M	28.5	189
Metofluthrin	12.3	116.7
Imazalil	65.8	134.8



Examples of Ongoing EPA Research for Toxicogenomics Application–Eco Screening PODs



Fathead Minnow

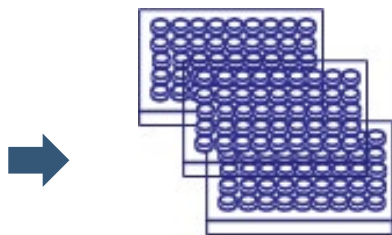

Conc response
24 hr exposure

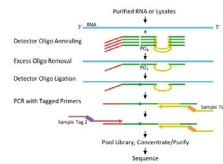

Whole Genome
Transcriptomics (HTTr)

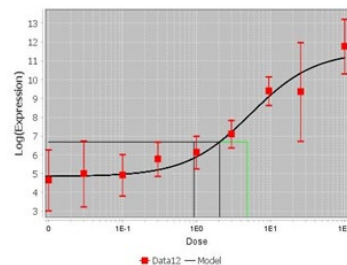

Concentration Response
Modeling

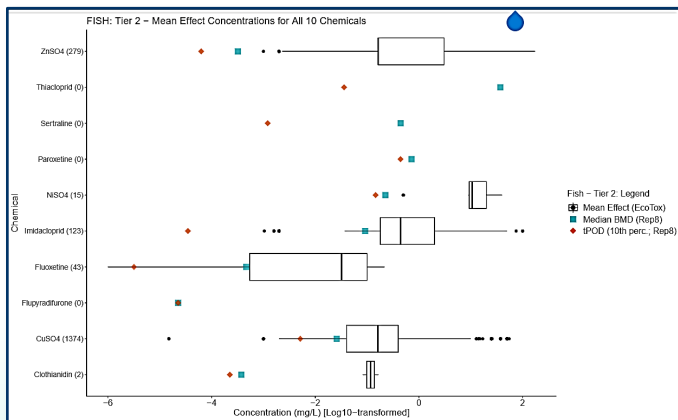

- HTTr-based bioactivity PODs in fathead minnow provide a protective POD compared with 25th centile of ECOTOX effect concentrations
- HTTr-based bioactivity PODs in fathead minnow were not always protective of effect concentrations in crustaceans



Examples of Ongoing EPA Research for Toxicogenomics Application–Health Impacts

- Value of Information (VOI) method developed to evaluate the trade-offs between timeliness, uncertainty, and costs of toxicity testing methods
- The trade-offs are evaluated on overall economic and human health costs associated with chemical exposure and control
- Different decision makers (benefit-cost, target risk) and health impacts can be incorporated
- Timeliness has a significant positive impact on the VOI of toxicity tests, even in the presence of smaller reductions in uncertainty
- The positive impact of the shorter tests may be multiplicatively amplified by the ability to test more chemicals
- Future research are applying this to evaluate the benefits of rapid toxicogenomic toxicity tests

Trade-Offs of Uncertainty and Time of Toxicity Testing Methods
(Chronic Effect, Target Risk Decision Maker)

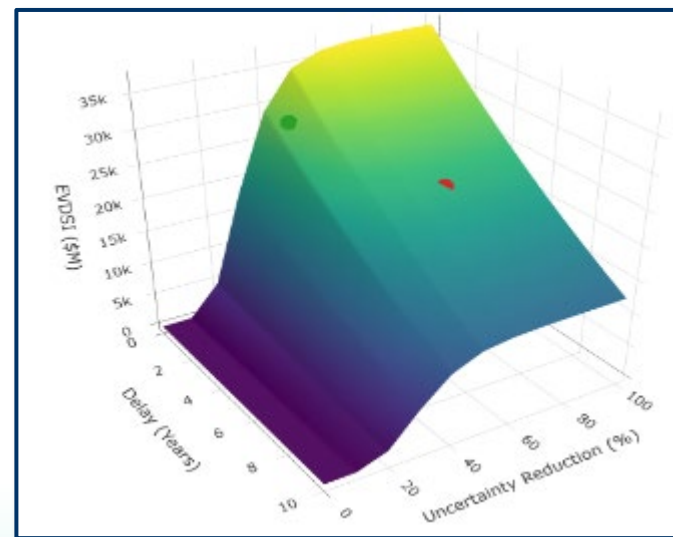

Hagiwara et al. Risk Anal., 2022



Building Scientific Confidence in Toxicogenomic Methods and Approaches—EPA NAMs Work Plan

- The EPA NAMs Work Plan provides multiple objectives and deliverables that aim to build scientific confidence
 - Evaluating the variability and relevance of existing methods to set a baseline for new methods
 - Developing case studies to evaluate application to regulatory decision making (some current case studies use toxicogenomics)
 - Developing an Agency-wide scientific confidence framework to evaluate the quality, reliability, and relevance of new methods



US EPA, 2021.



Building Scientific Confidence in Toxicogenic Methods and Approaches—OECD Activities

- The Organization for Economic Cooperation and Development (OECD) introduced an internationally accepted toxicogenomics reporting framework in 2021
 - Provides guidance on reporting of toxicogenomic information that fosters transparency and reproducibility
 - Currently captures experimental information, data acquisition/processing, and data analysis
 - Ensures sufficient information is available to enable evaluation of experimental data and interpretation
- Extension of the OECD efforts may pursue development of application reporting modules and additional case studies
 - Grouping and read across
 - Screening level risk assessment
 - Mode-of-action/adverse effect biomarkers



Building Scientific Confidence in Toxicogenomic Methods and Approaches—OECD Activities

What are the challenges of using 'omics data in chemical risk assessment?

01

Lack of confidence on 'omics data (e.g., lack of reliability, not able to link to endpoint or population level effect)*

29.5%

02

Lack of explanation when 'omics data is submitted for evaluation (e.g., why was the 'omics data generated, how reliable and reproducible is it, what does it mean/what difference does it make to the hazard and/or risk assessment)

22%

20%

05

Lack of in house experts on 'omics to support regulatory programs

03

Lack of technical guidance on acceptable practices for 'omics data

26.3%

04

Lack of confidence on 'omics data (e.g., lack of reliability, not able to link to endpoint or population level effect)*

21.2%
18.2%

Lack of relevant examples (or case studies) to refer to

Results from an OECD member survey - Acknowledgements to Magda Sachana



Building Scientific Confidence in Toxicogenomic Methods and Approaches—OECD Activities

Which of the following would increase your confidence on technical aspects of the use of 'omics data in chemical risk assessment?

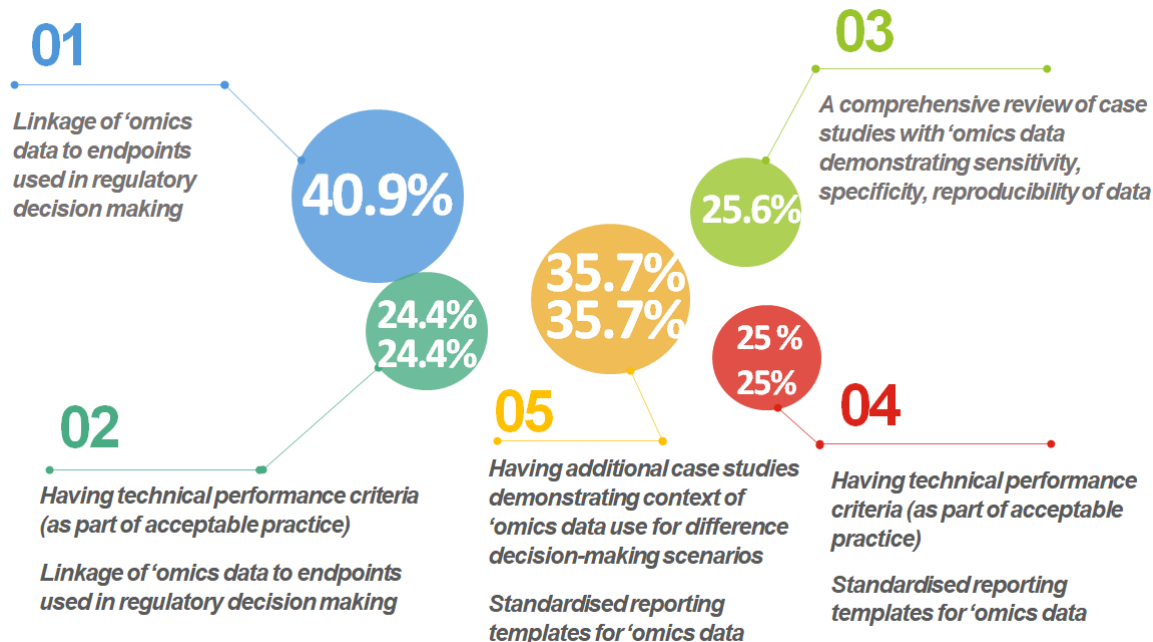

Results from an OECD member survey - Acknowledgements to Magda Sachana



Building Scientific Confidence in Toxicogenomic Methods and Approaches—OECD Activities

Which of the following would increase confidence on aspects related to application of the use of 'omics data in chemical risk assessment (beyond the reporting frameworks)?

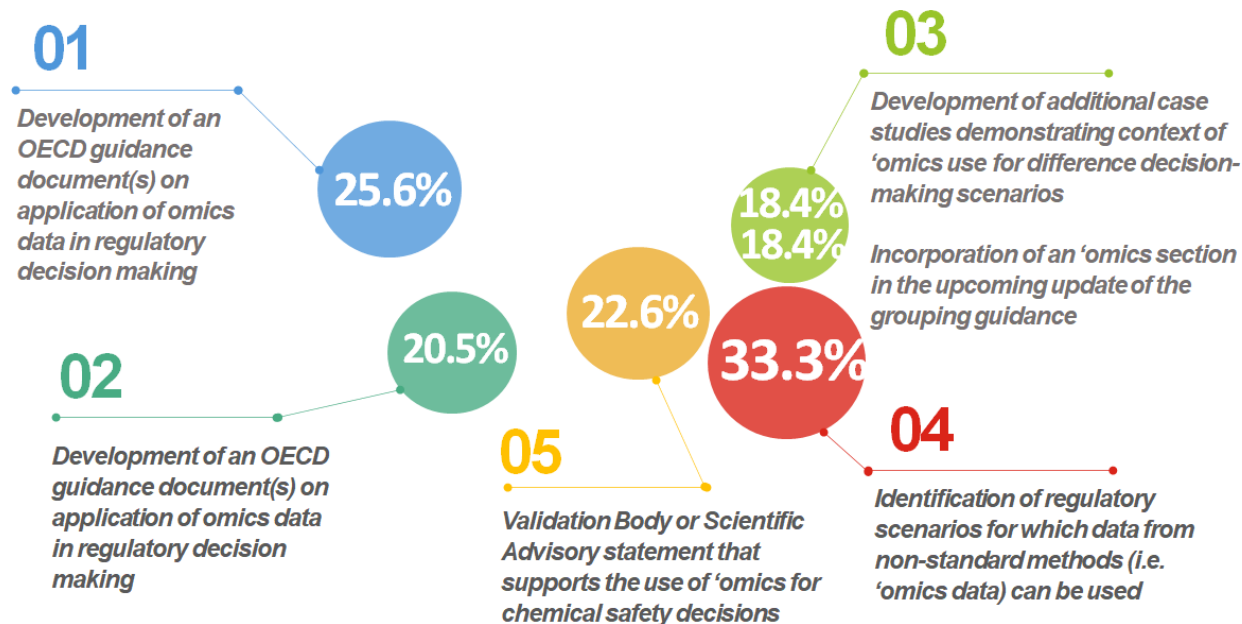

Results from an OECD member survey - Acknowledgements to Magda Sachana



Building Scientific Confidence in Toxicogenomic Methods and Approaches—OECD Activities

Identify for which of the following risk assessment applications the use of 'omics data might be beneficial in your regulatory jurisdiction over the next 5 years

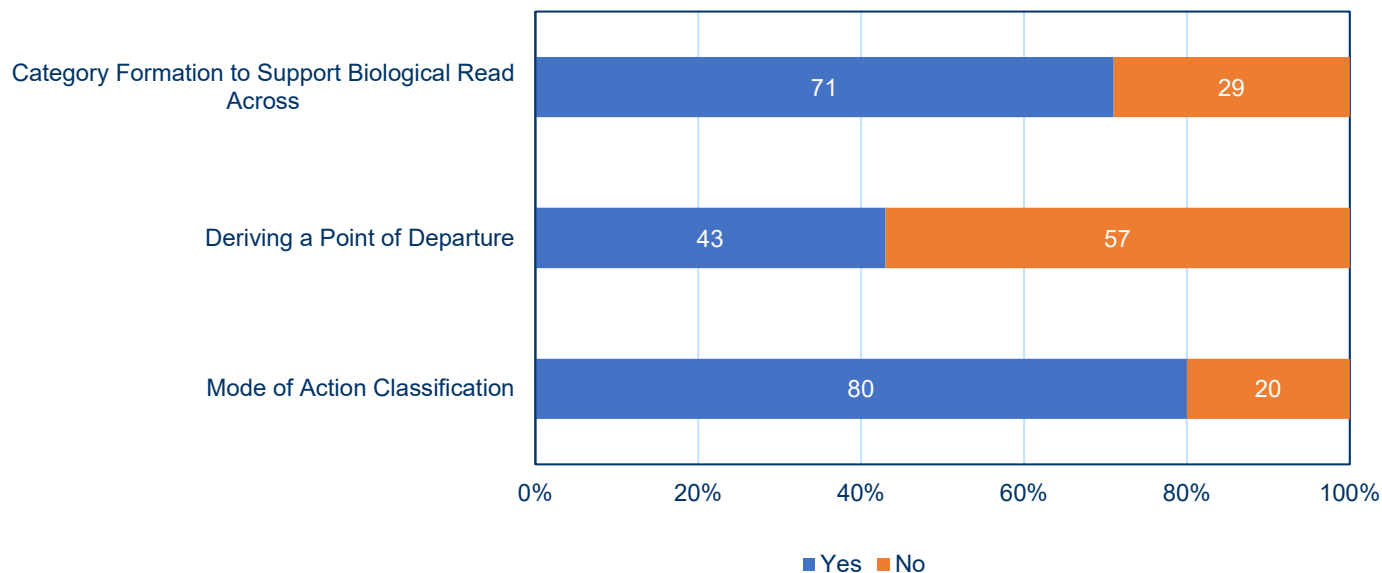

Results from an OECD member survey - Acknowledgements to Magda Sachana



Building Scientific Confidence in Toxicogenomic Methods and Approaches—OECD Activities

- *In vivo* and *in vitro* toxicogenomics data can be readily incorporated into Integrated Approaches to Testing and Assessment (IATA)
- Provides integrated information about biological changes in a single assay and evaluated in an AOP framework
- Builds on previous work incorporating NAMs into IATA
- OECD IATA case studies project launched in 2015 to gain experience and build confidence in the application of new methods

Overview of Concepts and Available Guidance related to Integrated Approaches to Testing and Assessment (IATA)

Series on Testing and Assessment
No. 329

Table 2.1. List of possible IATA components (in alphabetical order)

General terms	<i>Ex vivo</i> method <i>In chemico</i> assay <i>In silico</i> approach <i>In vitro</i> assay <i>In vivo</i> method New approach methodology (NAM) Non-guideline method Test guideline method
Combinations of individual methods	Defined Approach (DA) Grouping and read-across
Examples of methods/methodologies/technologies*	3D-organoids Absorption, distribution, metabolism, excretion (ADME) models Biokinetic model Cell-based assay Chemical structure information High Content Imaging (HCI) High Content Screening (HCS) High Throughput Screening (HTS) High Throughput Toxicokinetics (HTTK) <i>In vitro</i> to <i>in vivo</i> extrapolation (IVIVE) Machine learning Metabolite identification Omics (including e.g. genomics, proteomics, metabolomics, transcriptomics) Organ-on-a-chip <u>Physico-chemical properties</u> Physiologically-based toxicokinetic (PBTK) model Prediction model Quantitative AOP model Quantitative structure-activity relationship (QSAR) Reporter gene assays Reverse Toxicokinetics (RTK) Structure-activity relationship (SAR)

Building Scientific Confidence in Toxicogenomic Methods and Approaches—OECD Activities

- OECD IATA case study for repeat dose toxicity of phenolic benzotriazoles evaluated the use of *in vivo* transcriptomics to support a read across assessment
 - *In vivo* transcriptomic profiles were used to support similar modes of action
- OECD IATA case study for systemic toxicity of phenoxyethanol evaluated the use of *in vitro* transcriptomics to support a quantitative safety assessment
 - *In vitro* transcriptomic profiles in 3 cell types used to derive a molecular point of departure (NOTEL) together with a battery of safety pharmacology assays

Two OECD IATA Case Studies Utilized Transcriptomic Data



OECD, 2017

OECD, 2021



Summary

- Development and potential application of toxicogenomics for chemical safety decisions at EPA has been ongoing for more than twenty years
- New frameworks and research intends to address many of the perceived and real gaps in applying the technology
- EPA and international efforts to build scientific confidence in toxicogenomics are continuing
- A shift towards applying toxicogenomics more broadly in chemical risk assessment beyond its use in an overall weight-of-evidence remains elusive



References

- Harrill, JA et al., Progress towards an OECD reporting framework for transcriptomics and metabolomics in regulatory toxicology. *Reg Toxicol Pharmacol.*, 125:105020, 2021.
- Hagiwara, S. et al., A value of information framework for assessing the trade-offs associated with uncertainty, duration, and cost of chemical toxicity testing. *Risk Anal. In Press.* 2022.
- Hill, T. et al., Gene expression thresholds derived from short-term exposures identify rat tumorigens. *Toxicol Sci.* 177:41, 2020.
- OECD. Case study on the use of an integrated approach to testing and assessment for the repeated-dose toxicity of phenolic benzotriazoles. Series on Testing and Assessment, No. 271, ENV/JM/MONO(2017)23
- OECD. Case study on use of an integrated approach for testing and assessment (IATA) for systemic toxicity of phenoxyetanol when included at 1% in a body lotion. Series on Testing and Assessment, No. 349, ENV/CBC/MONO(2021)35
- OECD. Overview of concepts and available guidance related to integrated approaches to testing and assessment. Series on Testing and Assessment, No. 329, ENV/JM/MONO(2020)25
- Paul-Friedman, K. et al., Utility of *in vitro* bioactivity as a lower bound estimate of *in vivo* adverse effect levels in risk-based prioritization. *Toxicol Sci.* 173:202, 2020.
- Thomas, RS. et al., Incorporating new technologies into toxicity testing and risk assessment: moving from a 21st century vision to a data-driven framework. *Toxicol Sci.* 136:4, 2013.



References

Thomas, RS. et al., Temporal concordance between apical and transcriptional points of departure for chemical risk assessment. *Toxicol Sci.* 134:180, 2013.

Thomas, RS. et al., The next generation blueprint of computational toxicology at the US Environmental Protection Agency. *Toxicol Sci.* 169:317, 2019.

Speen, AM et al., Benchmark dose modeling approaches for volatile organic chemicals using a novel air-liquid interface *in vitro* exposure system. *Toxicol Sci.* In Press. 2022.

US EPA, Science Policy Council. 2002. Interim Policy on Genomics.

US EPA, Science Policy Council. 2004. Potential Implications of Genomics for Regulatory and Risk Assessment Applications at EPA. EPA 100/B-04/002.

US EPA, Science Policy Council. 2007. Interim Guidance for Microarray-Based Assays: Data Submission, Quality, Analysis, Management, and Training Considerations. DRAFT.

US EPA, 2009. An approach to using toxicogenomic data in US EPA human health risk assessments: a dibutyl phthalate case study. EPA/600/R-09/028F.

US EPA, 2021. New Approach Methods Work Plan (v2). EPA/600/X-21/209.

Wetmore, BA et al., Relative impact of incorporating pharmacokinetics on predicting *in vivo* hazard and mode of action from high-throughput *in vitro* toxicity assays. *Toxicol Sci.*, 132:327, 2013.



Acknowledgements

Tox21 Colleagues:

NTP
FDA
NCATS

EPA Colleagues:

CEMM
CPHEA
CESER

Collaborative Partners:

Unilever
A*STAR
ECHA
EFSA
Health Canada
OECD
EAGMST
Secretariat

Center for Computational Toxicology and Exposure (CCTE) Staff



Research Triangle Park, NC



Duluth, MN



Gulf Breeze, FL



Cincinnati, OH



Washington, DC



Athens, GA

